

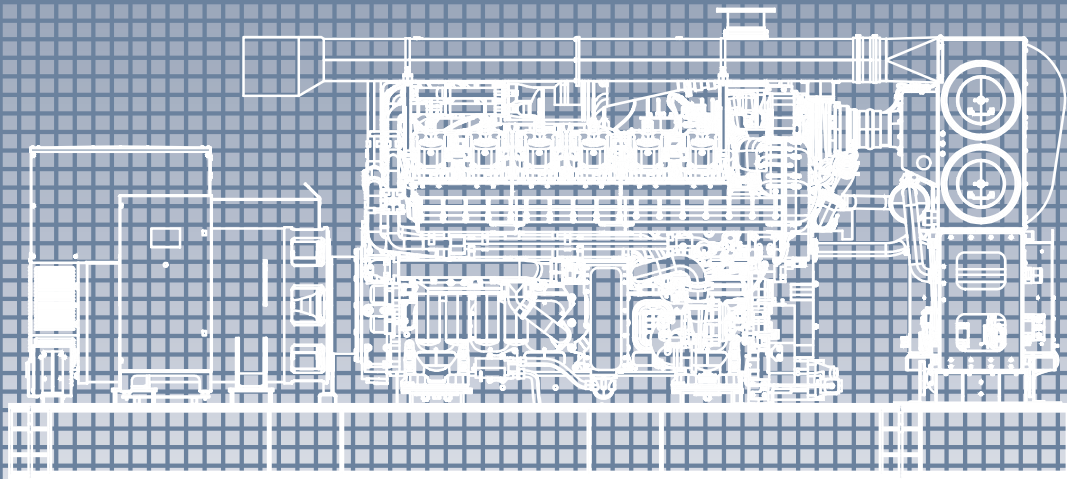

NATURAL GAS GENSETS
INSTALLATION
RECOMMENDATIONS AND
OPERATIONS MANUAL



ACG 1160 - ACG 1160 LMN

NATURAL GAS GENSETS
INSTALLATION RECOMMENDATIONS
AND OPERATIONS MANUAL

(ACG 1160 and ACG 1160 LMN MODEL)

HEAD OFFICE

AKSA JENERATÖR SAN. A.Ş.

Rüzgarlıbahçe Mah. Özalp Çıkması No:10

34805, Kavacık - Beykoz / İSTANBUL

T : +90 216 444 4 630

F : +90 216 681 57 81

aksa@aksa.com.tr

AUTHORIZED SERVICE

AKSA SERVICE & SPARE PARTS

Muratbey Beldesi, Güney Girişi Caddesi

No: 8 34540 Çatalca / İSTANBUL

T: +90 212 887 11 11

F: +90 212 887 10 20

info@aksaservis.com.tr

DEAR AKSA GENERATOR SET USERS

Thank you for purchasing this quality-built Aksa Natural Gas Generator. When operated and maintained according to the instructions in the operator's manual, your Aksa generator will provide many years of dependable service.

This manual is designed and developed to make you familiar with the generating system. Please read the following instructions carefully before starting to use your machine.

This manual contains safety information to make you aware of the hazards and risks associated with generator systems and how to avoid them. This generator system is designed and intended only for use standby system that provides an alternate source of electric power and to serve loads.

Never operate, maintain or repair your generating set without taking general safety precautions.

The manufacturer reserves the right to change, alter or otherwise improve the system at any time without prior notice.

aksa
J E N E R A T Ö R

1.	INTRODUCTION	1
2.	GENERAL SAFETY PRECAUTIONS.....	2
2.1.	General.....	2
2.2.	Hadling.....	2
2.3.	Fire and Explosion.....	2
2.4.	Mechanical.....	3
2.5.	Chemical.....	3
2.6.	Noise.....	3
2.7.	Electrical.....	3
2.8.	First Aid For Electric Shock.....	4
3.	GENERAL DESCRIPTION.....	5
3.1.	Generator Set Description And Identification.....	5
3.2.	Generator Set Main Parts.....	5
3.3.	Natural Gas Engine.....	6
3.4.	Engine Electrical System.....	6
3.5.	Cooling System.....	6
3.6.	Synchronous Alternator.....	6
3.7.	Coupling.....	6
3.8.	Base Frame.....	6
3.9.	Vibration Isolation.....	6
3.10.	Silencer And Exhaust System.....	6
3.11.	Control System.....	6
4.	ELECTRIC STARTING SYSTEM.....	7
4.1.	Battery Systems.....	7
4.2.	Maintenance Batteries.....	7
4.3.	Battery Maintenance.....	7
4.4.	Maintenance Free Batteries.....	7
4.5.	Control of the Battery.....	7
4.6.	Starting Aids.....	7
5.	HEALTHY AND SAFETY.....	7
5.1.	Fire Protection.....	7
5.2.	Exhaust Gases.....	8
5.3.	Moving Parts.....	8
5.4.	Hazardous Voltages.....	8
5.5.	Water.....	9
5.6.	Coolant.....	9

6.	WATER TREATMENT	9
6.1.	General.....	9
6.2.	Engine Coolant.....	9
7.	GENERATING SET CONTROL SYSTEMS	9
7.1.	Control System AGC-4 Mk II.....	9
7.2.	Button Functions.....	10
7.3.	Modes	11
7.4.	LED Colour Schemes.....	13
7.5.	Battery Charger.....	14
7.6.	Control System Options.....	14
7.7.	Heaters.....	14
7.8.	Voltage / Frequency Adjustment.....	14
8.	USE REQUIREMENTS	14
8.1.	General Precautions And Controls Which Must Be Done Before Starting Up The Generating Set.....	14
8.2.	General Precautions And Controls Which Must Be Done After Starting Up The Generating Set.....	15
9.	LUBRICATING OIL	15
9.1.	Oil Performance Properties	15
9.2.	Lubrication Oil Recommendations for Pipeline Gas Engines.....	15
10.	VENTS AND DUCTS	18
11.	FUEL ANALYSIS	18
11.1.	ACGI 160 Pipeline Natural Gas Genset Maintenance Plan.....	20
12.	ALTERNATOR DESCRIPTION	23
12.1.	General.....	23
12.2.	Construction and Components.....	23
12.3.	Operation	23
12.4.	Automatic Voltage Regulator.....	23
13.	GENERAL PRECAUTION	23

ATTACHMENTS

- CONTROL PANEL WIRING DIAGRAM
- AKSA JENERATÖR AUTHORIZED SERVICE POINTS
- AKSA JENERATÖR WHERE TO BUY ABROAD
- CERTIFICATIONS
- WARRANTY CERTIFICATE

1. INTRODUCTION

Aksa Generating set is designed to be commissioned, when delivered, as soon as the necessary cooling water, antifreeze, gas fuel, lubrication oil and fully charged battery are provided. With its long years of experience, Aksa manufactures efficient; reliable and quality generating set This user and maintenance manual is prepared to assist the operator in operation and maintenance of the generating set Observing the advices and rules in this manual will ensure that the generating set operates in maximum performance and efficiency for a long time.

- Care should betaken to perform more frequent maintenance in dirty and dusty environments in order-to keep the generating set in good working condition,
- Necessary adjustment and repairs should be made only by authorized and qualified persons.
- Each generating set has a model and a serial number indicated on a label on the base frame. This plate also indicates the manufacturing date, voltage, current power in kVA, frequency, power factor and weight of the generating set These class are necessary in spare part orders, for warranty validity and for service calls. Attach unit to base-frame with suitable diameter masonry anchor bolts long enough to retain the unit.

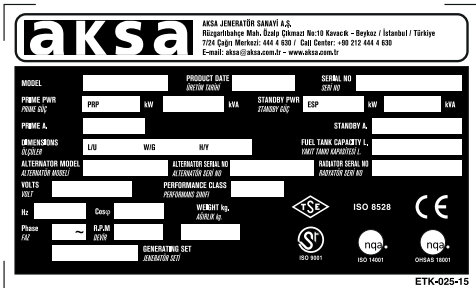

The generating set is designed to be safe when used in correct manner. However responsibility for safety rests with the personnel who install use and maintain the set If the following safety precautions are followed, the possibility of accidents will be minimized. Before performing any procedure or operating technique, it is up to the user to ensure that it is safe. The generating set should only be operated by personnel who are authorized and trained. Only people that have the right skills should be allowed

to operate, adjust perform maintenance or repair on Aksa Power Generation equipment It is the responsibility of management to appoint operators with the appropriate training and skill for each category of job. Skill level 1: Operator

An operator is trained in all aspects of operating the unit with the push- buttons, and trained to know the safety aspects,

Skill level 2: Mechanical technician A mechanical technician is trained to operate the unit the same as the operator. In addition, the mechanical technician is also trained to perform maintenance and repair, as describe in the instruction manual, and is allowed to change settings of the control and safety system. A mechanical technician does not work on live electrical components.

Skill level 3: Electrical technician An electrical technician and has the same qualifications as both the operator and the mechanical technician. In addition, the electrical technician may carry out electrical repairs within the various enclosures of the unit. This includes work on live electrical components.

Skill level 4: Specialist from the manufacturer This is skilled spedalist sent by the manufacturer or its agent to perform complex repairs or modifications to the equipment In general it is recommended that not more than two people operate the unit, more operators could lead to un safe operating conditions. Take necessary steps to keep unauthorized person away from the unit and eliminate all possible source of danger at the unit

The manufacturer does not accept any liability for any damage arising from the use of non-original parts and for modifications, additions or conversions made without the manufacturer's approval in writing,

2. GENERAL SAFETY PRECAUTIONS

2.1. GENERAL

1 The owner is responsible for maintaining the unit in a safe operating condition. Unit parts and accessories must be replaced if missing or unsuitable for safe operation.

2 Operate the unit only for the intended purpose and within its rated limits (pressure, temperature, speeds, etc).

3 Gen-set and equipment shall be kept clean, i.e. as free as possible from oil, dust or other deposits.

4 To prevent an increase in working temperature, inspect and clean heat transfer surfaces (cooler fins, intercoolers, water jackets, etc.) regularly.

5 Take precautions against fire. Handle gas fuel, oil and anti-freeze with care because they are inflammable substances. Do not smoke or approach with naked flame when handling such substances. Keep a fire-extinguisher in the vicinity.

WARNING

! Read and understand all safety precautions and warnings before operating or performing maintenance on the generating set. Failure to follow the instructions, procedures, and safety precautions in this manual may increase the possibility of accidents and injuries.

! Do not attempt to operate the generating set with a known unsafe condition.

! If the generating set is unsafe, put danger notices and disconnect the battery negative (-) lead so that it cannot be started until the condition is corrected.

! Disconnect the battery negative (-) lead prior to attempting any repairs or cleaning inside the enclosure.

! Install and operate this generating set only in full compliance with relevant National, Local or Federal Codes; Standards or other requirements.

2.2. HANDLING

The following safety precautions should be noted:

WARNING

! Make electrical connections in compliance with relevant Electrical Codes; Standards or other requirements. This includes requirements for grounding and ground/earth faults.

! Engine exhaust emissions are hazardous to personnel. The engine exhaust for all indoor generating sets must be piped outdoors via leak-free piping in compliance with relevant Codes, Standards and other requirements. Ensure that hot exhaust silencers and piping are clear of combustible material and are guarded for personnel protection per safety requirements. Ensure that fumes from the exhaust outlet will not be a hazard!
! Never lift the generating set by attaching to the engine or alternator lifting lugs, instead use the lifting points on the base frame or canopy.

! Ensure that the lifting rigging and supporting structure is in good condition and has a capacity suitable for the load.

! Keep all personnel away from the generating set when it is suspended.



2.3. Fire and Explosion

Warning

- Natural Gas is extremely flammable and explosive.
 - Fire or explosion can cause severe burns or death.
 - Install the gas fuel supply system according to applicable local codes.
 - Before placing the generator into service, the fuel system lines must be properly purged and leak tested
 - After the generator is installed, you should inspect the gas fuel system periodically.
 - NO leakage is permitted.
 - DO NOT operate engine if smell of fuel is present or other explosive conditions exist
 - DO NOT smoke around the generator. Wipe up any oil spills immediately. Ensure that no combustible materials are left in the generator compartment. Keep the area near the generator clean and free of debris.
- However, safety dictates that fully charged ABC and ABC fire extinguishers are kept on hand. Personnel must know how to operate them.



WARNING

! Ensure that the generating set room is properly ventilated. Keep the room, the floor and the generating set clean. When spills of oil, battery electrolyte or coolant

occur; they should be cleaned up immediately.

! Do not smoke or allow sparks, flames or other sources of ignition around gas line and batteries or batteries.

! Turn off or disconnect the power to the battery charger before making or breaking connections with the battery.

! To avoiding arcing keep grounded conductive objects (such as tools) a way from exposed live electrical parts (such as terminals).

2.4. Mechanical

The generating set is designed with guards for protection from moving parts. Care must still be taken to protect personnel and equipment from either mechanical hazards when working around the generating set.

WARNING

! Do not attempt to operate the generating set with the safety guards removed. While the generating set is running do not attempt to reach under or around the guards to do maintenance or for any other reason.

! Keep hands; arms, long hair; loose clothing and jewelry away from pulleys, belts and other moving parts.



Attention: Some moving parts cannot be seen clearly when the set is running.

! If equipped keep access doors on enclosures closed and locked when not required to be open.

! Avoid contact with hot oil, hot coolant hot surfaces and sharp edges and corners.

! Wear protective clothing including gloves and hat when working around the generating set.

! Do not remove the radiator filler cap until the coolant has cooled.

Then loosen the cap slowly to relieve any excess pressure before removing



2.5. Chemical

Oils, coolants; lubricants and battery electrolyte used in this generating set are typical of the industry. However; they can be hazardous to personnel if not treated properly.

WARNING

! Do not swallow or allow skin contact with oil, coolant lubricants or battery electrolyte. If swallowed, seek medical treatment immediately.

! Do not wear dothing that has been contaminated by lube oil.

! Wear an acid resistant apron and face shield or goggles when servicing the battery. If electrolyte is spilled on skin or clothing flush immediately with large quantities of water.



2.6. Noise

Generating sets that are not equipped with sound attenuating enclosures can produce noise levels in excess of 105 dB(A). Prolonged exposure to noise levels above 85 dB(A) is hazardous to hearing.



WARNING

Ear protection must be worn when operating or working around an operating generating set.

2.7. Electrical

Safe and efficient operation of electrical equipment can be achieved only if the equipments is correctly installed, operated and maintained.

WARNING

! The generating set must be connected to the load only by trained and qualified electricians who are authorized to do so, and in compliance with relevant Electrical Codes, Standards and other regulations. ! Ensure that the generating set, is effectively grounded/earthed in accordance with all relevant regulations prior operation.

! The generating set should be shutdown with the battery negative (-) terminal disconnected prior to attempting to connect or disconnect load connections.

! Do not attempt to connect or disconnect load connections while standing in water or on wet or soggy ground.

! Do not touch electrically energized parts of the generating set and/or interconnecting cables or conductors with any part of the body or with any non

insulated conductive object.

! Replace the generating set terminal box cover as soon as connection or disconnection of the load cables is complete. Do not operate the generating set without the cover securely in place.

! Connect the generating set only to loads and/ or electrical systems that are compatible with its electrical characteristics and that are within its rated capacity.

! Keep all electrical equipment clean and dry. Replace any wiring where the insulation is cracked, cut abraded or otherwise degraded, Replace terminals that are worn, discolored or corroded. Keep terminals clean and tight

! Insulate all connections and disconnected wires.

! Use only Class BC or Class ABC extinguishers on electrical fires.



2.8. First Aid For Electric Shock

WARNING

! Do not touch the victim's skin with bare hands until the source of electricity has been turned off.

! Switch off power if possible otherwise pull the plug or the cable away from the victim.

! If this is not possible, stand on dry insulating material and pull the victim clear of the conductor, preferably using insulated material such as dry wood.

! If victim is breathing, turn the victim clear of the conductor, preferably using insulated material such as dry wood.

! If victim is breathing, turn the victim into the recovery position described below. If victim is unconscious, perform resuscitation as required;

Open the airway

Tilt the victim's head back and lift the chin upwards. Remove objects from the mouth or throat (including false teeth, tobacco or chewing gum).



Breathing

Check that the victim is breathing by looking, listening and feeling for the breath.



Circulation

Check for pulse in the victim's neck.

If no breathing but pulse is present

- Pinch the victim's nose firmly.
- Take a deep breath and seal your lips around the victim's lips.
- Blow slowly into the mouth watching for the chest to rise.

- Let the chest fall completely.

Give breaths at a rate of 10

- If the victim must be left to get help, give 10 breaths first and then return quickly and continue.

- Check for pulse after every 10 breaths. When breathing restarts, place the victim into the recovery position described later in this section.



If no breathing and no pulse

- Call or telephone for medical help.
- Give two breaths and start chest compression as follows:

- Place heel of hand 2 fingers breadth above ribcage/breastbone junction.

- Place other hand on top and interlock fingers,

- Keeping arms straight, press down 4-5 cm at a rate of 15 times per minute.

- Repeat cycle (2 breaths and 15 compressions) until medical help takes over.

- If condition improves, confirm pulse and continue with breaths.

Check for pulse after every 10 breaths.

- When breathing restarts, place the victim into the recovery position described below.



Recovery position

- Turn the victim onto the side.
- Keep the head tilted with the jaw forward to maintain the open airway.
- Make sure the victim cannot roll forwards or backwards.

- Check for breathing and pulse regularly. If either stops, proceed as above.



WARNING

! Do not give liquids until victim is conscious.

3. GENERAL DESCRIPTION

3.1. Generating Set Description and Identification

Natural gas generators are independent units for the production of electric power; they comprise a constant voltage synchronous driven by an internal -combustion engine. The sets are used for two main purposes;

a- Continuous duty sets,

Used to produce electric power for countless requirements (motive power, lighting heating etc) in areas where other sources or power are unavailable.

b- Emergency duty sets,

Used during public network failures, when such failures are liable to cause serious trouble to persons or material or financial damage (i.e. in hospitals, industrial plants with non-stop operating cycles, etc) or to meet peak energy demands.

According to their application, the sets are further divided into:

- set for use on land

The sets for use on land can be

- stationary sets (fixed installation),

These sets are available in a vast range of versions, for every operating requirement the main ones being:

01. hand control generating sets
02. stand-by generating sets

The standard stationary generating set comprises;

- natural gas engine
- synchronous generator
- coupling
- metal sub-base with vibration isolators
- starter batteries
- instrument panel
- exhaust gas silencer.

Aksa Generating Set has been designed as a complete package to provide superior performance and reliability. Figure. 3.1. identifies the major components. This figure is of atypical generating set However, every set will be slightly different due to the size and configuration of the major components. This section briefly

describes the parts of the generating set Further information is provided in later sections of this manual.

Each generating set is provided with a Rating Label (item 1) generally fixed to the base frame. This label contains the information needed to identify the generating set and its operating characteristics. This information includes the model number, serial number, output characteristics such as voltage and frequency, output rating in Id/A and kW, product date and weight The model and serial numbers uniquely identify the generating set and are needed when ordering spare parts or obtaining service or warranty work for the set Aksa generating sets are an Alternating Current generator, built for continuous running at sites where no electricity is available (some models are excepted) or as stand-by in case of interruption of the mains.

The generator operates at 230/220 V. in line-to-neutral mode and 400/380 V in line-to-line mode.

3.2. Generating Set Main Parts

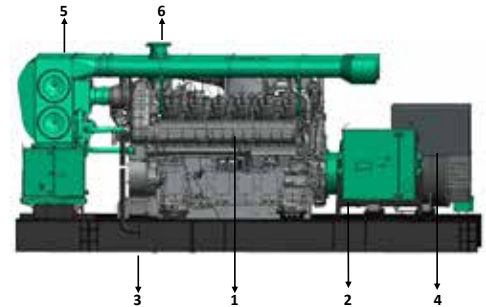

Figure 3.1. Typical Engine Generator Set

No	Description
1	Engine
2	Control Box
3	Chasis
4	Alternator
5	Air Filter
6	Exhaust

3.3. Natural Gas Engine

The natural gas engine has been chosen for its reliability and the fact that it has been specifically designed for powering generating sets. The engine is of the heavy duty industrial type with 4 stroke and is fitted with all accessories to provide a reliable power supply. These accessories include, among others, a cartridge type dry air filter and an electronic engine speed governor. The engine cylinder block is cast in one piece cast iron, vertical cylinders inline overhead valves and camshaft in block. The cylinder head is made of special cast iron. The thermally loaded flame plate is efficiently water cooled. The crankshaft is forged in one piece in a high tensile steel.

Lubrication: forced lubrication via gear pump, special paper cartridge -type filters, lubricant cooling via heat exchanger on most versions.

3.4. Engine Electrical System

The engine electrical system is 24 volts DC negative ground/earth. This system includes an electric engine starter, a battery and a battery charging alternator. For 24 volts electrical system two batteries are given. Other types of batteries may be fitted if they were specified.

3.5. Cooling System

The engine cooling system is water cooled. The water cooled system is comprised of a radiator a pusher fan and thermostat. The alternator has its own internal fan to cool the alternator components.

3.6. Synchronous Alternator

Horizontal axle alternator (synchronous three phase), on rolling bearings, self-ventilated within the room with low-loss silicon-sheet stator bundle, electrolytic copper winding with class H insulation.

The output electrical power is normally produced by a screen protected and drip-proof self-exciting self regulating brushless alternator. Fine tuned to the output of this generating set. Mounted on top of the alternator is a sheet steel terminal box.

3.7. Coupling

Engine and alternator are firmly joined by a coupling

cone that guarantees the proper assembly coaxiality. Mono-support machines are also used a special flexible disk is used in place of a flexible coupling.

3.8. Base frame

The engine and alternator are coupled together and mounted on a heavy duty steel base-frame.

3.9. Vibration Isolation

The generating set is fitted with vibration isolators which are designed to reduce engine vibration being transmitted to the foundation on which the generating set is mounted. These isolators are fitted between the engine /alternator feet and the base frame.

3.10. Silencer and Exhaust System

Exhaust gases from the turbocharger are discharged toward atmosphere through a silencer. These should be vented as high as possible, and must be prevented from re-entering the engine via the charge air intake, or polluting the radiator fins.

It is important to note that the turbocharger nozzles must be always free of loads. Stainless steel exhaust compensator(s) is delivered with generator set. Exhaust lines of different engines shall not be mixed in a common stack, but routed separately in individual ducts, enclosed in a chimney.

Suitable material is carbon steel sheet, and recommended calculation temperature is 475°C. Rain and condensate permanent draining shall be provided to prevent water entering the silencer and the engine.

An exhaust silencer is provided loose for installation with the generating set. The silencer and exhaust system reduce the noise emission from the engine and can direct exhaust system reduce the noise emission from engine and can direct exhaust gases to safe outlets. The exhaust silencer is made of a carbon steel receiver containing sound attenuator and wave de-phasing system made of perforated steel sheet and heavy rock wool. It is asbestos-free. The exhaust silencer is delivered in two configurations with an industrial attenuation and residential attenuation.

3.11. Control System

One of several type control systems and panels may

be fitted to control the operation and output of the set and to protect the set from possible malfunctions. Section 11 of this manual provides detailed information on these systems and will aid in identification of the control system fitted on the generating set.

4. ELECTRIC STARTING SYSTEMS

Electric starting systems are generally used on all gen-sets.

The power source for electric starting systems is a 24 VDC battery system. Starting is via a start solenoid which is controlled by the gen-set control system.

4.1. Battery Systems

Battery type is lead acid. Lead acid batteries are generally used, being the least expensive.

4.2. Maintenance Batteries

Warning

- Do not smoke or allow sparks, flames or other sources of ignition around batteries. Hydrogen gas generated by charging batteries is explosive.
- Wear an acid resistant apron and face shield or goggles when servicing the battery. If electrolyte is spilled on skin or clothing, flush immediately with large quantities of water.
- Take out the metallic things in your wrist and protect your wrist and hand.
- Disconnect the battery negative (earth) lead first and reconnect last.
- Always ensure that battery charging is carried out in a well ventilated area.

The starting batteries should be located as close as possible to the generating set while still being accessible for servicing. This will prevent electrical losses.

4.3. Battery Maintenance

- Keep the top of the battery and its terminals clean.
- Cover the battery terminals and its connections with Vaseline.
- Tighten the terminals but not tighten it hardly.
- Control the electrolyte level periodically. It must be 10 mm above the plates.
- Control the abrasion in the charge alternator belt and check periodically the belt tension according to

producer' recommendation.

- Ensure that your battery is not uncharged.

4.4. Maintenance Free Batteries

Ensure that all battery connections are correct and batteries are always charged. After that there is not any procedure for this battery.

4.5. Control of the Battery

Conduct an inspection every time before testing the battery.

1. A white powdered element causes abrasion to the pole-heads, its connections. Remove the connections and wash them with hot water to purify the oxidation. Reconnect it and coat with vaseline.
2. Check if any un-tightened connections exist.

4.6. Starting Aids

It is customary to maintain coolant temperatures above 40°C min. to promote quick starting on an emergency generating set and to take the load. Thermostatically controlled immersion heaters, deriving their supply from the primary source of power are fitted in the engine cooling system to provide this heating. Heater warms up the jacket water of the engine when the generating set is not working.

5. HEALTHY and SAFETY

Safety should be the primary concern of the facility design engineer and all personnel engaged on installation and commissioning. Safety involves two aspects:

- 1) Safe operation of the generator itself (and its accessories).
- 2) Reliable operation of the system.

Reliable operation of the system is related to safety because equipment affecting life and health, such as life support equipment in hospitals, emergency aggress lighting, building ventilators, elevators and fire pumps, may depend on the generator set.

5.1. Fire Protection

The design, selection and installation of fire protection systems require the following considerations:

- The fire protection system must comply with the requirements of National Standards.

- Typically, the generator room will be required to have a one hour fire resistance rating. Generator room construction will have to have a two hour fire resistance rating.
- Generator room shall not be used for storage purposes
- The authority may specify the quantity, type and sizes of approved portable fire extinguishers required for the generator room.
- A manual emergency stop station outside the generator room or enclosure or remote from the generator set in an outside enclosure would facilitate shutting down the generator set in the event of a fire or another type of emergency.

General

- Do not permit any flame, cigarette, pilot light, spark, arcing equipment, or other ignition source near the generating set or gas fuel line.
- Gas fuel lines must be adequately secured and free of leaks. Gas fuel connection at the engine should be made with an approved flexible line.
- Be sure all gas fuel supplies have a positive shut-off.

5.2. Exhaust Gases

- Be sure the exhaust system will properly dispel discharged gases away from enclosed or sheltered areas and areas where individuals are likely to congregate.
- Never connect the exhaust system of two or more engines.
- Never discharge engine exhaust into a brick, tile or cement block chimney, or a similar structure. Exhaust pulsations could cause severe structural damage.
- Do not use exhaust gases to heat a compartment.
- Be sure that the unit is well ventilated.
- Ensure that there is independent support for the exhaust system. No strain should be imposed on the engine exhaust manifolds. Which is especially important on a turbo-charged engine.

5.3. Moving Parts

- Tighten supports and keep guards in position over fans drive belts etc. Make sure that fasteners on the set are secure.
- Keep hands, clothing and clothing and jewellery away

from moving parts.

- If adjustment must be made while the unit is running, use extreme caution around hot manifolds, moving parts, etc

5.4. Hazardous Voltages

Improper wiring can cause fire or electrocution, resulting in severe personal injury or death and property or equipment damage.

For personal protection, stand on a dry wooden platform or rubber insulating mat, make sure clothing and shoes are dry, remove jewellery from hands and use tools with insulated handles.

- Do not leave cables trailing on the engine room floor.
 - Do not use the same trunking for electric cables and water lines.
 - Do not run AC and DC cables in the same looms or trunking
 - Always ensure that bonding and equipment earthing are correctly done. All metallic parts that could become energised under abnormal conditions must be properly earthed.
 - Always disconnect the batteries and battery charger when serving or carrying out maintenance particularly on equipment arranged for automatic mains failure operation. Always disconnect a battery charger from its AC source before disconnecting the battery cable. Accidental starting of the generator set while working on it can cause severe personal injury or death.
 - Do not tamper with interlocks.
 - Do not connect the generator set directly to any building electrical system.
 - Always follow all applicable state and local electrical codes. Have all electrical installations performed by a qualified licensed electrician.
- High voltage sets work differently to low voltage ones. Special equipment and training is required to work around high voltage equipment. Operation and maintenance must be done only by persons trained and qualified to work on such devices. Improper use or procedures may well result in personal injury or death.
- Do not work on energised equipment. Unauthorised personnel must not be permitted near energised equipment. Due to the nature of high voltage electrical equipment includes voltage remains after the equip-

ment is disconnected from the power source. Equipment should be de-energised and safety earthed.

5.5. Water

Water or moisture inside a generator increases the possibility of “flashing” and electrical shock, which can cause equipment damage and severe personal injury or death. Do not use a generator which is not dry inside and out.

5.6. Coolant

The coolant heater must not be operated while the cooling system is empty or when the engine is running or damage to the heater will occur. Coolant under pressure have a higher boiling point than water.

- Do not open a radiator, pressure cap while the engine is running. Allow the generator set to cool and bleed the system pressure first.

6. WATER TREATMENT

6.1. General

The engine cooling system is subject to rust and cavitation attacks. To minimize the severity of this condition an anti-corrosive agent can be added to totally clean and limpud coolant water.

An antifreeze solution is also required to prevent freezing of the coolant in the cold weather.

6.2. Engine Coolant

Water for coolant should be clean and free from any corrosive chemicals such as chlorides, sulphates and acids. It should be kept slightly alkaline with a pH value in the range 8,5 to 10,5

Generally, any water which is suitable for drinking can be used, with treatment as described below.

Protection against corrosion

Supplemental Coolant Additive is required to protect the cooling system from fouling, solder blooming and general corrosion.

The use of antifreeze is also recommended as ASTM D6210 concentrations are dependent upon the presence of antifreeze. Antifreeze also interacts with ASTM D6210 to provide greater corrosion and cavitation protection.

Procedure for Treating Coolant

1. Add the required amount of water to mixing container and dissolve in the required quantity of ASTM D6210
2. Add the required amount of antifreeze, if used, to the water solution and mix thoroughly.
3. Add the coolant to the cooling system

Cold Weather Protection

Antifreeze must be added to the coolant where there is any possibility of freezing to protect the engine from damage due to coolant freezing.

The engine cooling water can be used diluting it with antifreezing solution 40% and the additive for rust prevention (ASTM D6210) 3 ~ 5 %. The dosage of ASTM D6210 must be increased to higher concentration if antifreeze is not added to the coolant. A low - silicate antifreeze is recommended.

The density of antifreezing solution and additive for rust prevention is able to be confirmed by the cooling water test kit. (ASTM D6210 replacement interval is 1 year)

- Amount of Anti-freeze in winter

Ambient Temperature (°C)	Cooling water (%)	Anti-freeze (%)
Over- 10	85	15
-10	80	20
-15	73	27
-20	67	33
-25	60	40
-30	56	44
-40	50	50

7. GENERATING SET CONTROL SYSTEMS

To control and monitor the generator set, an electronic control system has been used. Control panel provides a means of starting and stopping the generating set, monitoring its operation and output and automatically shutting down the set in the event of critical condition arising such as low oil pressure or high engine temperature.

7.1. Control System AGC-4 Mk II

The automatic genset controller AGC-4 Mk II can be used as a single genset controller. Also, several AGCs can be connected in a complete power management system for synchronising projects, islanded or paralleled to the mains.

The generator controller is ideal for mission-critical applications such as hospitals and data centres, and it is capable of delivering backup power in only six seconds.



Features

- Automatic Mains Failure sequence
- Multi-master Power Management
- Power Management Core (32dg)
- Power Management Extended (>32dg)
- RMB Transformer maintenance with up to 32 gensets
- PLC logic
- Engine CAN bus
- DIN rail mount
- Flexible Hardware
- Additional CAN bus based I/O (9 x CIO modules)
- Redundant controller
- Redundant CAN bus for Power management
- N+X configuration
- Close Before Excitation / Run-up synchronization from 6 seconds
- DEIF digital AVR DVC550 support
- Multi purpose PIDs
- Gridcode compliant with: VDE AR-N 4110/4105 (Medium voltage, Germany, VDE AR-N 4105 (low voltage, Germany, EN 50549-1:2019 (Europe), ENA EREC G99 (United Kingdom)
- TÜV and UL approved
- Touch Screen Support (TDUI07)
- Tier4 final/stage5
- Emulation for easy training and FAT
- Hybrid EMS support (via ASC-4)
- Heavy consumer (via ALC-4)
- Gas fuel optimisation
- Fully compatible with AGC 150 and ASC-4

7.2. Button Functions

Standart AGC-4 Mk II folio

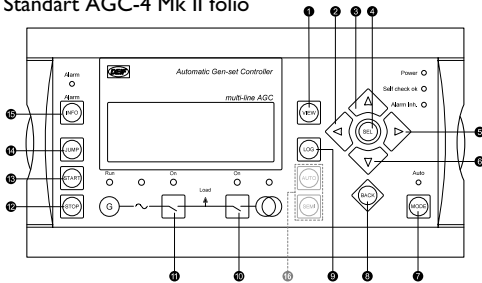

AGC - GER (German) folio

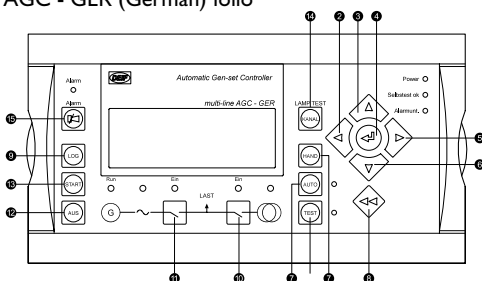

1. Shifts the first line displaying in the setup menus. If more than one DU-2 is connected to the controller, push for 2 seconds to make this DU-2 the master display.
2. Moves the cursor left.
3. Up button: Function depends on context.
 - VI: Scrolls the view lines.
- Setup menu: Displays a different value in the second line.
 - A parameter: Increases the set point.
4. Selects the underscored entry in the fourth line of the display.
5. Moves the cursor right.
 - VI: Scrolls the view lines.
- Setup menu: Displays a different value in the second line.
 - A parameter: Decreases the set point.
7. Changes the menu line (line four) in the display to mode selection.
 - Not present in group and plant controllers.
8. Jumps one step backwards in the menu (to previous display or to the entry window).
9. Displays the LOG SETUP window where you can choose between the Event, Alarm and Battery logs. The logs are not deleted when the auxiliary supply is switched off.
10. Manual activation of close/open breaker sequence if SEMI is selected.
11. Manual activation of close/open breaker sequence if SEMI is selected.
12. Stops the genset/plant if SEMI or MANUAL* is selected.
13. Starts the genset/plant if SEMI or MANUAL* is selected.
14. Enables the user to use the menu number to select and display any setting.
15. Shifts the display three lower lines to show the alarm list. By holding the button, all alarms will be acknowledged.
16. Group and plant controllers: Select AUTO and SEMI mode.
17. German AGC only: Test button.

*Note: MANUAL mode is not available in German controllers.

7.3. Modes

Mode	Description
SEMI	<ul style="list-style-type: none"> • The display buttons (START, STOP, GB ON, GB OFF) are active and can be used by the operator. • The regulators are also active, that is, the speed control will bring the generator to nominal speed upon start. • When pushing a breaker button for closing, the AGC will synchronise (if allowed) the breaker. When the breaker closes, the controls stop.
TEST	<ul style="list-style-type: none"> • The controller will start the generator, carry out the test sequence (pre-defined time period) and stop the generator again. Subsequently, the generator will return to AUTO or SEMI-AUTO mode. The mains breaker will remain closed, and the generator breaker will remain open. NOTE: The test running can be: Simple test: starting the genset without closing the GB; Load test: parallel to the mains and take load to a pre-defined value; Full test: transfer the load to the genset and open the MB.
AUTO	<ul style="list-style-type: none"> • The controller will automatically carry out the control type selected (AMF, fixed power, and so on). • The display control buttons (START, STOP, GB ON, GB OFF) are disabled. • Mains controller in local (parameter 8021): If the selected running mode is fixed power, mains power export, load takeover or island, timer start/stop (week watch) or binary input, then start/stop can be used.
MAN*	<ul style="list-style-type: none"> • The display buttons (START, STOP) are active and can be used by the operator. • The regulators are not active, that is, speed (and voltage) control has to take place using binary inputs for UP and DOWN control. • The breakers will be able to open or close at any time. A synchronisation check will always be performed to ensure safe closing of the breakers.
BLOCK	<ul style="list-style-type: none"> • The controller will not be able to start the equipment. BLOCK mode can be selected during standstill and the password is needed to exit BLOCK mode. If BLOCK mode is selected while the genset is running, the mode will have no effect until the genset is stopped. To select another mode after BLOCK mode, the password must be entered.

*Note: Manual mode is not available on the German controller.

To return to the other display functions from MODE selection, press the BACK button.

Standart AGC-4 Mk II folio

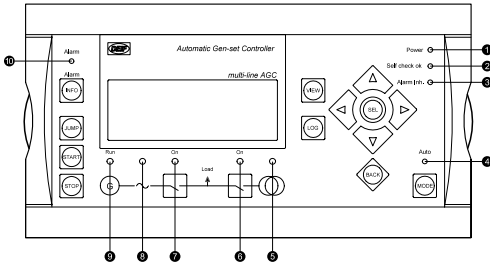

or the GB load time has not expired.

8. LED green light indicates that the voltage/frequency is present and OK.

9. LED indicates that the generator is running.

10. LED flashing indicates that unacknowledged alarms are present. LED fixed light indicates that ALL alarms are acknowledged, but some are still present.

11. German AGO only: TEST LED.

AGC - GER (German) folio

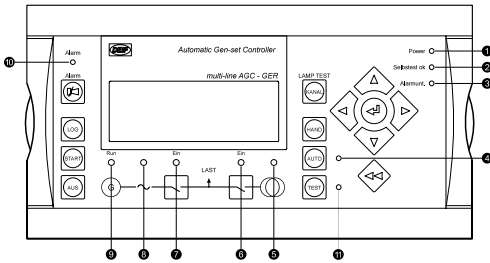

Led functions

1. LED indicates that the auxiliary supply is switched on.

2. LED indicates that the controller is OK.

3. See Alarm inhibit in the Designer's reference handbook.

- In group and plant controllers, this is the power management CAN bus communication status.

4. LED indicates that auto mode is selected.

- In group and plant controllers, this is replaced by the status LEDs next to the AUTO and SEMI buttons.

5. LED is green if the mains is present and OK. LED is red for a measured mains failure. LED is flashing green when the mains returns during the "mains OK delay" time.

6. LED green light indicates that the mains breaker is closed. LED is flashing yellow if the "MB spring loaded" signal from the breaker is missing or the MB load time has not expired.

7. LED green light indicates that the generator breaker is closed. LED yellow light indicates that the generator breaker has received a command to close on a black bus, but the breaker is not yet closed due to interlocking of the GB. LED is flashing yellow if the "enable GB black close" or the "GB spring loaded" signal is missing

7.4. LED Colour Schemes

There are two colour schemes for the display LEDs. If LED colour scheme 2 is required, use parameter 6082 (DU-2 only) to select it.

Breaker or bus status	Colour scheme 1 (default)	Colour scheme 2
Breaker closed	Green	Red
Breaker open	White/no color	Green
Mains fail 0-30%	Red	Green
Mains above 30% but not inside "HzA/ OK" window.	Red	Red
Mains inside "HzA/ OK" window	Green	Red
Busbar fail 0-30%	No Color	Green
Busbar above 30% but not side "HzN OK" window	Red	Red
Busbar inside "HzN OK" window	Green	Red
DG fail 0-30%	No color	Green
DG above 30% but not inside "HzN OK" window	Red	Red
DG inside "Hz/V OK" window	Green	Red

7.5 Battery charger

When the Gensets are not running for a long time , battery charger is used in order to charge the battery ,Battery charger is powered by mains , and mounted in the control panel. A battery charger ampere indicator can be added to control pane in order to see whether battery charger is working or not .

Battery charger is manufactured with switching-mode and SMD technology and it has high efficiency. Battery charger models' output V-I characteristic is very close to square and output is 5 amper, 13,8 V for 12 volt and 27,6 V for 24 V . Input 198 - 264 volt AC. Pro-line 2405 has fully output shot circuit protection and it can be used as a current source. Proline 1205/2405 charger has high efficiency, long life, low failure rate, light weight and low heat radiated in accordance with linear alternatives. The charger is fitted with a protection diode across the output. Connect charge fail relay coil between positive output and CF output. They are equipped with RFI filter to reduce electrical noise radiated from the device. Galvanic ally isolated input and output typically 4kV for high reliability.

7.6. Control System Options

According to customer request, different options could be added to control system.

- Parallel with mains continuously and black start system with mains.
- Automatic synchronizing and power control system (Multi Gensets parallel).
- Load sharing system (scada).
- Remote monitoring and control.
- Remote alarm panel.
- Backup generator system.

7.7. Heaters

Alternator heaters could be mounted on the alternator stators to keep it dry and protect it from humidity and a heater could be mounted in the control panel to prevent it against humidity too.

7.8. Voltage / Frequency Adjustment

A potentiometer could be mounted in the control panel to adjust the frequency or voltage or both of them. Frequency adjustment potentiometer is con-

nected the electronic governor control module.

8. USE REQUIREMENTS

8.1. General Precautions And Controls Which Must Be Done Before Starting Up The Generating Set

- Whenever an abnormal conditions arises, e.g. excessive vibration, noise, odour, etc., switch the circuit breakers to OFF and stop the engine. Correct the faulty condition before restarting
- Never touch the power terminals during operation of the machine.
- Check if the exhaust system has any leakage.
- Check for leakage of oil or cooling water.
- Monitor the generating set operation by means of the control module LCD display. Check the engine temperature and oil pressure. Oil pressure must reach the normal value 10 seconds after the generating set operation.
- Monitor the generating set outlet voltage and frequency by means of the control module LCD display. Check the voltage, if the voltage between phases is 400 V. and between phase and neutral is 230 V. Check that the frequency is 50 Hz on generating sets with electronic governors.
- If an engine block water heater is not available, run the generating set at no-load for 8 minutes and when the engine warm than apply on load (for manual models) Apply load to the generating set as follows:
- Set the alternator outlet circuit breaker on the panel to ON position.
- Set the load circuit beakers (or fuses) on the distribution panel to ON position one by one. This way, the generating set cannot be suddenly put under full load. Otherwise, the engine stalling or alternator winding insulation of formation or burning can occur.
- Set the alternator outlet circuit breaker on the circuit to OFF position before stop the generating set.
- Continue to run the unloaded engine for purpose of cooling period for 5 minutes and then stop.
- Never operate the generating set before removing any fault, if any.
- Running the generator at low load for long periods will reduce the lifetime of the engine.

8.2. General Precautions And Controls Which Must Be Done After Starting Up The Generating Set

- Check for any abnormal noise or vibration on the generating set.
- Check if the exhaust system has any leakage.
- Monitor the generating set operation by means of the control module LCD display. Check the engine temperature and oil pressure. Oil pressure must reach the normal value 10 seconds after the generating set operation.
- Monitor the generating set outlet voltage and frequency by means of the control module LCD display. Check the voltage, if the voltage between phases is 400 V. and between phase and neutral is 230 V. Voltage is adjusted in the factory, do not try to readjust it.
- Check that the frequency is 51 - 52 Hz on generating sets with mechanical governors and 50Hz on generating sets with electronic governors.
- If an engine block water heater is not available, run the generating set at no-load for 3-5 minutes and when the engine warm than apply on load (for manual models)

Apply load to the generating set as follows on manual mode

- Set the alternator outlet circuit breaker on the panel to ON position.
- Set the load circuit breakers (or fuses) on the distribution panel to ON position one by one. This way, the generating set cannot be suddenly put under full load. Otherwise, the engine stalling or alternator winding insulation of formation or burning can occur.
- Set the alternator outlet circuit breaker on the circuit to OFF position before stop the generating set.
- Continue to run the unloaded engine for purpose of cooling period for 2 minutes and then stop.
- Never operate the generating set before removing any fault, if any.
- Check the oil / coolant/gas fuel leakage while engine is running.
- Never run the engine below 30%of prime power for a long time.
- Share the load on every phase (U,V,W) equally.
- On automatic controlled gen set load will be on and off automatically.

9. LUBRICATING OIL

Oil system of gas engine is one of the most important elements of the engine. Correctly made engine overhaul (this subject includes oil change periods, filter change periods, paying attention about selecting the true type of oil) prolongs the life cost of the engine.

9.1. Oil Performance Properties

The American Petroleum Institute (API) the American Society for Testing and Materials (ASTM) and Society of Automotive Engineers (SAE) has developed and preserved a system in order to classify the lubrication oils for their performance categories

9.2. Lubrication Oil Recommendations for Pipeline Gas Engines

The use of high quality engine lubricating oils combined with appropriate oil drain and filter change intervals are a critical factor in maintaining engine performance, reliability, and durability.

Engine manufacturer recommends the use of high quality Society of Automotive Engineers (SAE) 40 heavy duty engine oil for natural gas engines. The use of the "Premium Grade - Long Change Interval" oils are strongly recommended.

CAUTION

A sulphated ash limit of 0.60 percent has been placed on all stationary engine lubricating oil recommended for use in engine of High Horsepower Natural Gas Lean-Burn engines. Higher ash oil can cause valve and/or piston damage and lead to excessive oil consumption and degradation of any exhaust aftertreatment system catalyst.

Premium Grade - Long Change Interval Oils			
Valvoline Premium Blue™ Gas Engine Oil (GEO) LA and Mobil Pegasus 805, Shell™ S5N			
Engine Model	With Oil Analysis		Without Oil Analysis
	Oil Sampling Interval	Oil Change Interval	Oil Change Interval
QSK60G 1500 rpm/50 Hz 160 kW _e	250 hours*	Up to 1500 hours, while sample results are within limits.	750 hours
QSK60G 1800 rpm/60 Hz 1400 kW _e	250 hours*	Up to 750 hours, while sample results are within limits.	375 hours

Premium Grade - Long Change Interval Oil			
Valvoline Premium Blue™ GEO LA - ES and Shell Mysella XL S5 S 40			
Engine Model	With Oil Analysis		Without Oil Analysis
	Oil Sampling Interval	Oil Change Interval	Oil Change Interval
QSK60G 1500 rpm/50 Hz 160 kW _e	250 hours*	Up to 2000 hours, while sample results are within limits.	1500 hours

Note :The oil filter change interval may be different from the lubricating oil change intervals shown above. Oil filters must be changed as specified with the recommendations shown in this procedure.

Premium Grade - Long Change Interval Oils			
Motul Gasma Premium Blue™ GEO MA			
Engine Model	With Oil Analysis		Without Oil Analysis
	Oil Sampling Interval	Oil Change Interval	Oil Change Interval
QSK60G Multiple Turboc-hargers 1500 rpm/50 Hz	250 hours*	Up to 1500 hours, while sample results are within limits.	750 hours
QSK60G Multiple Turboc-hargers 1800 rpm/60 Hz	250 hours*	Up to 750 hours, while sample results are within limits.	375 hours

* At least

Manufacturer	Oil Name	Oil Grade	Total Base Number	Sulphate Ash Percent
Valvoline™	Premium Blue™ GEO LA-ES	SAE40	4.4	0.44
Valvoline™	Premium Blue™ GEO LA	SAE40	5.5	0.44
Valvoline™	Premium Blue™ GEO MA	SAE40	6.1	0.7
Shell™	Mysella XL (S5N)	SAE40	4.5	0.48
Mobil	Pegasus 1005®	SAE40	5.8	0.5

Generating Sets 50 Hz			Fuel Consumption at Full Load m ³ /h	Engine Water Capacity Liter	Oil Capacity Liter
Model	Continuous Power (kWe)	Generating Sets 50 Hz			
ACG1160	1160	QSK60G	308,9	181	380
ACG1160 LMN	1160	QSK60G	308,9	181	380

Table 11.1. Fuel consumption and coolant, fuel and lubricating oil capacities and lubricating oil specifications (50 Hz Open Gen-sets).

10. VENTS AND DUCTS

1. For indoor installations, locate vents so incoming air passes through the immediate area of the installation before exhausting. Install the air outlet higher than the air inlet to allow for convection air movement.
2. Size the vents and ducts so they are large enough to allow the required flow rate of air:
3. Wind will restrict free airflow if it blows directly into the air outlet vent. Locate the outlet vent so the effects of wind are eliminated, or if the outlet vent cannot be located as mentioned, install a wind barrier. See Figure 8

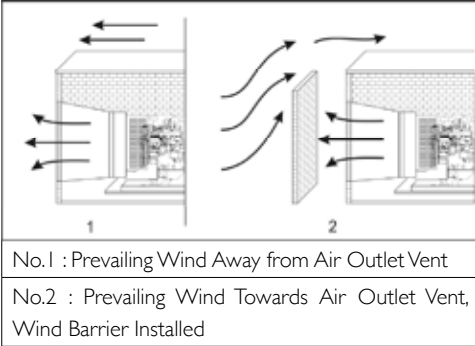

Fig.12.1. Wind Barrier

NOTICE

The “free area” of ducts must be as large as the exposed area of the radiator. Refer to the generator set Specification Sheet for the airflow requirements and allowed airflow restriction.

11. FUEL ANALYSIS

The gas fuel supplier can provide a analysis that describes the chemical makeup of the gas fuel to be provided. This analysis can be used to make certain that the gas fuel is suitable for use in the specific engine proposed for a specific application, and also to verify that the BTU content of the gas fuel is sufficient to provide necessary kW output of the machine. Gas suppliers may change the Pipeline Natural Gas composition without notice, so there is no long-term guarantee of performance, but the process of evaluation of the gas fuel can be briefly described as:

1. List the percent of each gas constituent in the gas fuel.
2. Calculate the percent of the total gas fuel that is combustible. The combustible portion of the gas fuel is 100% less the inert component percentages. Inert components include Oxygen, Carbon Dioxide and water vapor.

3. Calculate the percent of each combustible component of the gas fuel.
4. Verify acceptability of the gas fuel by checking the percent of each combustible element vs. the recommendations of the engine manufacturer.

For example, for a gas analysis of:

90% Methane

6% Ethane

2% Hydrogen

1% Normal Pentane

1% Nitrogen

- Total percent inert elements: 1%
- Total combustible: $100\% - 1\% = 99\%$
- % Methane: $90\% + 99\% = 91\%$
- % Ethane: $6\% + 99\% = 6.1\%$
- % Hydrogen: $2\% - 99\% = 2\%$
- % Normal Pentane: $1\% - 99\% = 1\%$

See the following tables for a typical listing of Maximum Permissible Combustibles in Gas generator sets. Note that in this example, the analysis shows the gas fuel will be acceptable for a lower compression ratio engine (typically around 8.5:1) but not for a higher compression engine. A higher compression engine will have more stringent gas fuel composition requirements but may operate satisfactorily with a derating of its output - consult the engine manufacturer.

5. Verify the rating of the generator set based on the use of the proposed gas fuel.

The total BTU content of the gas fuel will determine the rating of the generator set when using gas fuel of a specific composition. If any component of the gas fuel has more than the specific value allowed derating will be required. Consult the engine manufacturer for gas fuel requirements and derating instructions.

Note that the gas fuel derating and the altitude/temperature derating 21 are not additive. Only the maximum value of the fuel derate or the altitude/temperature derate need be applied.

Turbocharged engines have unique fuel composition requirements due to higher cylinder pressures. To avoid problems with pre-ignition or denotation, power output derating is required if propane and/or ISO-Butane content exceed the percentages listed in the following tables.

Maximum Allowable Percentages For Engine Fuel Cumbustible

	8.5:1 Compression Ratio	10.5:1 Compression Ratio
Methane (C ₁)	100	100
Ethane (C ₂)	100	100
Propane (C ₃)	10	2
ISO-Butane (IC ₄)	7	0.2
Hydrogen (H ₂)	7	trace
Normal Butane (NC ₄)	3	0.2
ISO-Pentane (IC ₅)	3	0.2
Normal Pentane (NC ₅)	1	0.1
Hexane (C ₆)	1	0.1
Heptane (C ₇)	1	0.1

Maximum Allowable Percentages Of Constituent Gases Before Derating Turbocharged Engines

	8.5:1 Compression Ratio	10.5:1 Compression Ratio
Methane	N/A	N/A
Ethane	N/A	N/A

ACG I 160 Pipeline Natural Gas Trains

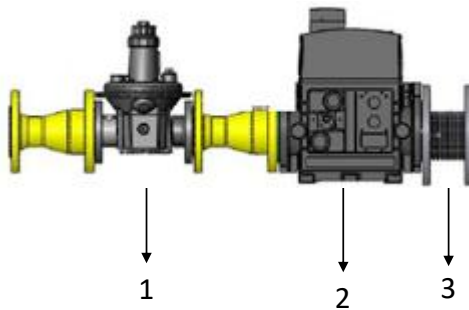

1	2	3
Pressure Regulator	Solenoid Valves	Flexible Pipe

11.1. ACGI 160 Pipeline Natural Gas Genset Maintenance Plan

Event	Service Interval (Hrs)	250	M1 (1,5k)	M2 (3k)	M3 (6k)	M4 (15k)	M5 (30k)	M6 (60k)
EL	Top set adjustment	X	X	R	R	R	R	R
	Check & change lube oil filters	X	X	R	R	R	R	R
	Check & re adjust emissions	X	X	R	R	R	R	R
	Check throttle actuator connections	X		R	R	R	R	R
M1	Inspect for debris		X	R	R	R	R	R
	Oil change		X	R	R	R	R	R
	Check DCA		X	R	R	R	R	R
	Replace spark plug		X	R	R	R	R	R
M2	Air Filters, Primary			X	R	R	R	R
	Lucricate gas counter			X	R	R	R	R
	Replace COP O-rings			X	R	R	R	R
	Replace Coolant Filters			X	R	R	R	R
	Check batteries			X	R	R	R	R
M3	Crankcase Breather Filters				X	R	R	R
	Gas Filter				X	R	R	R
M4	No Special Action Taken							
M5	Replace Piston Rings and Liners						X	R
	Cylinder Heads Overhaul						X	R
	Replace Connecting Rod Bearing						X	R
	Connecting Rods (inspect/replace)						X	R
	Turbochargers Refurbishment						X	R
	Clean Aftercooler (if required)						X	R
	Replace Alternator bearings						X	R
M6	Replace Alternator/ Rubber element						X	R
	Replace Pistons							X
	Vibration Damper							X
	Camshaft Bushing							X
	Cam Followers							X
	Replace Turbo							X
	Lub Oil Cooler							X
	Change Oil Cooler							X
	Main Bearings							X
Alternator Bearings							X	

R = Repeat

COP = Coil On Plug

ACGI I60 GENERATOR CONTROL LIST

	Daily	Weekly
Check Cooling Water Level		
Check Engine Oil Level	•	
Check abnormal issues (damage, fracture, bending)	•	
Check abnormal shaking / vibration / hunting	•	
Check if there a sound or burning smell that indicates a non-standard mechanical or electrical fault in the system.	•	
Check battery and connecting cables		•
Check cooling system hose		•
Check crankedcase ventilation		•
Check engine electrical connection		•
Check flex hose deformation		•
Check turbocharger oil drain line		•
Check turbocharger oil supply line		•
Check Air Leaks, Air Intake and Exhaust System		•

Gas Composition Limits – Metric Units

Gas Composition Limits						
Component of Gas	SI Units	Class A	Class B	Class C	Class D	Class E
CONTAMINANTS						
Total sulfur content (Including total S from H ₂ S) (see note 11)	mg/Nm ³ CH ₄	< 30	< 100	< 1000	< 2000	
Oxygen (see note 10)	%Vol	< 1	< 1	< 1	< 1	
Ammonia	mg/Nm ³ CH ₄	< 25	< 25	< 25	< 50	
Total Halogen content, incl. chlorinated and fluorinated hydrocarbons. (Sum of Cl in mg + 2 x sum of F in mg) (see note 9)	mg/Nm ³ CH ₄	< 1	< 1	< 100	< 200	
Total gaseous silicon content as Si, (This includes Si content present in an Siloxanes)	mg/Nm ³ CH ₄	< 1	< 1	< 20	< 40	
COMPOSITION						
Hydrogen (see note 13)	%Vol	< 3	< 3	< 3	< 3	
Hydrocarbon Condensate	ppm (Vol)	< 20	< 20	< 20	< 20	
Relative Humidity	%	80% with 100% droplet removal	80% with 100% droplet removal	80% with 100% droplet removal	80% with 100% droplet removal	
Oil Content	mg/Nm ³ CH ₄	< 5	< 5	< 5	< 5	
Particulate or Solid content	mg/Nm ³ CH ₄	< 30	< 30	< 30	< 30	
Max Particle Size (14)	micron	1	1	1	1	
Minimum Methane Number	Refer to Engine Data Sheet for Methane Number					
Fuel lower heating value (LHV)	Refer to Engine Data Sheet for Lower Heating Value					
Minimum gas delivery pressure (see note 6)	mbarg	See Note 7	See Note 7	See Note 7	See Note 7	
Gas Inlet Temperature Range (see note 8)	°C	5 – 50	5 – 50	5 – 50	5 – 50	
Maximum Variation for calorific content relative to the fuel used at the time of commissioning (see note 12)	%	4	4	4	4	
Maximum variation rate for calorific content (see note 12)	% per min	1	1	1	1	

Any composition that exceeds Class D requires Chief Engineer approval.

12. ALTERNATOR DESCRIPTION

12.1. General

The alternator fitted on the generating set is of the brushless self-excitation type which eliminates the maintenance associated with slip rings and brushes. The control system, consist of an automatic voltage regulator, protective circuits.

12.2. Construction and Components

The stator core is produced from insulated low loss electrical grade sheet steel laminations. These are built and welded under a fixed pressure to give an extremely rigid core to withstand vibration and load impulses. The complete wound stator is, after impregnation, pressed into the frame and pinned into position.

The rotor assembly, which comprises the alternator rotating field systems, the exciter rotating diode system and the cooling fan. The complete rotor assembly is dynamically balanced to ensure vibration-free running. At the drive end of the rotor assembly a cast-aluminum centrifugal fan draws cooling air through screened covers at the non drive end and discharges it through similar side mounted covers at the drive end.

12.3. Operation

The electrical power produced by the generating set is derived from a closed loop system consisting principally of the exciter rotor the main revolving field and the automatic voltage regulator (see Figure 13.1) The process begins when the engine starts to rotate the internal components of the alternator. The residual magnetism in the main rotor produces a small alternating voltage (AC) in the main stator. The automatic voltage regulator rectifies this voltage (converts it to DC) and applies it to the exciter stator.

This DC current to the exciter stator creates a magnetic field which in turn, induces an AC voltage in the exciter rotor. This AC voltage is converted back to DC by the rotating diodes.

When this DC voltage appears at the main rotor, a stronger magnetic field than the original residual field is created which induces a higher voltage in the main stator. This higher voltage druilates through the system inducing an even higher DC voltage back at the main rotor. This cycle continuous to build up the voltage

unit it approaches the proper output level of the generating set. At this point the automatic voltage regulator begins to limit the voltage being passed to the exciter stator which, in turn, limits the overall power output of the alternator.

This build-up process takes place in less than one second.

12.4. Automatic Voltage Regulator

The Automatic Voltage Regulator (AVR) maintains a no load to full load steady state voltage to tight tolerances. The AVR has a volt/hertz characteristic which proportionally reduces the regulated voltage at reduced speeds.

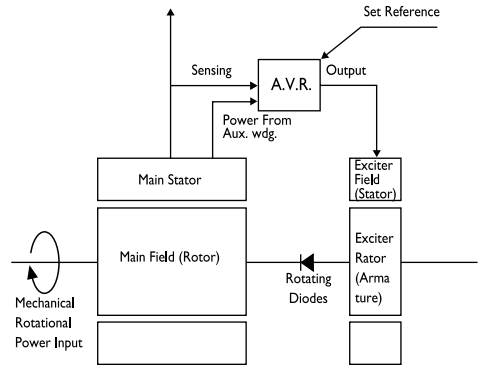

Figure 13.1. Meccalte alternator, operating principles block schematic diagram

13. GENERAL PRECAUTION

Dear AKSA generator set operator. Please take care to the following order to prevent the generator set warranty to become invalid if the warranty period and to ensure trouble-free operation of the generator set with a long life.

1. Maintenance and repair works will not be covered by the warranty certificate. If the invoice or delivery certificate of the generating set is not submitted.

2. The warranty of the generator set will become invalid in case of any intervention of any person other than authorized AKSA services or by prior written approval from AKSA power generation on the generator set for any reason.

3. Control and maintenance works indicated in the periodical maintenance schedule and the operating manual must be carried out completely and timely the failures due to incomplete or untimely maintenance are not covered by the warranty.

4. Generator set should be installed as indicated in the installation manual otherwise, the problems which are likely to occur will not be covered by the warranty.

5. Customer is responsible for the failures which are likely to occur in case that the gas oil used contains dirt or water.

6. The oil type indicated in the maintenance manual should be used in the engine otherwise, the failures which are likely to occur will not be covered by the warranty.

7. Batteries will not be covered by the warranty if they are subjected to breakage, excessive acid fill or hardening by leaving uncharged.

8. Don't over crank the generator set , if the generator is not started at the first attempt , wait 10 second and then try to start the engine again , the cranking mustn't be done more than 3 times ,and cranking time have to be less than 10 seconds ,otherwise starter gear could be broken or starter could be burn up. These conditions are not covered warranty.

9. Generator sets, never start or stop the gas engine when the generating set is under load. Engine should be started and stopped after load is disconnected and the generating set is at idle condition. Otherwise, the valves can be seized, the voltage regulator, transformer and diodes can be broken down. These conditions are not covered warranty.

10. Our company does not take the responsibility of the damages of the automatic generator sets due to over current, low or high voltage.

11. Never remove the battery terminals while the generating set is in use. Even a moment of disconnection

can cause damage on the electronic closing relay of the charge alternator and on the electronic engine speed control circuit these conditions are not covered by the warranty.

12. Failures due to overload and unbalanced load in excess of the generating set power (such as alternator and contactor failures) are not covered by the warranty.

13. When the manually operated generating set is started up, it should be warmed by operating at idle for 5 minutes. When stopping the gas engine, it should be unloaded and then continued to be operated for cooling for 5 minutes before stopping. Otherwise problems which are likely to occur will not be covered by the warranty

14. Warranty period is 1 year beginning from the purchase date.

Authorized Service Dealer may perform warranty repairs. Most warranty repairs are handled routinely, but sometimes requests for warranty service may not be appropriate. For example, warranty service would not apply if equipment damage occurred because of misuse, lack of routine maintenance, shipping, handling, warehousing or improper installation. Similarly, the warranty is void if the manufacturing date or the serial number on the equipment has been removed or the equipment has been altered or modified. During the warranty period, the Authorized Service Dealer, at its option, will repair or replace any part that, upon examination, is found to be defective under normal use and service. This warranty will not cover the following repairs and equipment:

- Normal Wear: Power Equipment and engines, like all mechanical devices, needs periodic parts and service to perform well. This warranty does not cover repair when normal use has exhausted the life of a part or the equipment.
- Installation and Maintenance: This warranty does not apply to equipment or parts that have been subjected to improper or unauthorized installation or alteration and modification, misuse, negligence, accident, over-

loading, over speeding, improper maintenance, repair or storage so as, in our judgment, to adversely affect its performance and reliability. This warranty also does not cover normal maintenance such as adjustments, fuel system cleaning and obstruction (due to chemical, dirt, carbon, lime, and so forth).

- Other Exclusions: This warranty excludes wear items such as, o-rings, filters, fuses, or spark plugs, etc., or damage or malfunctions resulting from accidents, abuse, modifications, alterations, or improper servicing or freezing or chemical deterioration. Accessory parts are excluded from the product warranty. This warranty excludes failures due to acts of God and other force majeure events beyond the manufacturers control.

AKSA JENERATÖR YETKİLİ SERVİS NOKTALARI

İSTANBUL AVRUPA YAKASI

AVCILAR

MUSTAFA KEMAL PAŞA MAH. YILDIRIM BEYAZIT CAD. DEMET SOK. NO:132 AVCILAR/İSTANBUL
444 4 630 • aksa@aksa.com.tr

KAĞITHANE

ÇAĞLAYAN MAH. KAĞITHANE CAD. NO:93/A KAĞITHANE
444 4 630 • aksa@aksa.com.tr

KARAKÖY

NECATİBEY CAD NO.74 KARAKÖY / İSTANBUL
444 4 630 • aksa@aksa.com.tr
DOLAPDERE SAN. SİT. 13.ADA NO:9 İKİTELLİ
444 4 630 • aksa@aksa.com.tr

İSTANBUL ANADOLU YAKASI

AYDINEVLER ÂŞIK VEYSEL SOK. AK PLAZA NO:24 KÜÇÜKYALI/MALTEPE
444 4 630 • aksa@aksa.com.tr

İSTANBUL DIŞI SERVİS NOKTALARI

ANKARA

ÇETİNEMEÇ BLV.1065.CAD 1309 SOK NO:7 A/BLOK ÇANKAYA
444 4 630 • aksa@aksa.com.tr

ADANA

TURHAN CEMAL BERİKER BUL. ADANA İŞ MERKEZİ
A BLOK NO:24/27 YEŞİLOBA SEYHAN
444 4 630 • aksa@aksa.com.tr

ANTALYA

ASPENOS BULVARI YEŞİLOVA MAH. 198/2-3 MURATPAŞA
444 4 630 • aksa@aksa.com.tr

BURSA

NİLÜFER TİC. MRK. ALAADDİNBEY MAH. 70 SK.
NO:12/B NİLÜFER
444 4 630 • aksa@aksa.com.tr

DENİZLİ

ADNAN MENDERES BULVARI ZAFER MAH.
İZMİR ASFALTI ÜZERİ NO:70
444 4 630 • aksa@aksa.com.tr

DİYARBAKIR

MEZOPOTAMYA MAH. MAHABAD BULVARI EYYÜP ANDAN
CITY NO 79/A KAYAPINAR
444 4 630 • aksa@aksa.com.tr

GAZİANTEP

MÜCAHİTLER MAH.12 NOLU CD.GÜLEVLER SİT. A BLOK ALTI
NO:20 ŞEHİTKAMİL
444 4 630 • aksa@aksa.com.tr

İZMİR

FATİH MAH. 1203 SK. NO:29 A / MERKEZ
444 4 630 • aksa@aksa.com.tr

KAYSERİ

ORGANİZE SANAYİ BÖLGESİ CAD:21 NO:20 MELİKGAZI
444 4 630 • aksa@aksa.com.tr

MUĞLA - BODRUM

CUMHURİYET CAD. KIVILCIM İŞ MERKEZİ
A/BLOK NO : 1 ORTAKENT
444 4 630 • aksa@aksa.com.tr

MUĞLA - MARMARİS

SARIANA MAH.23 SOKAK NO:2/1 MARMARİS
444 4 630 • aksa@aksa.com.tr

SAMSUN

TOYBELEN MAH. 1301. SOK.
No: 177 İLKADIM
444 4 630 • aksa@aksa.com.tr

ŞANLIURFA

MEHMETÇİK MAH. 10004 SK. ATAŞEHİR İŞ MERKEZİ
T1 BLOK NO:4 KARAKÖPRÜ
444 4 630 • aksa@aksa.com.tr

TEKİRDAĞ

ALİPAŞA MAH. ÇETİN EMEÇ BULVARI
NO: 60-66 / C-D ÇORLU
444 4 630 • aksa@aksa.com.tr

TRABZON

KARŞIYAKA MAH. YAVUZ SELİM BULVARI
MANOLYA SİTESİ 467/A
444 4 630 • aksa@aksa.com.tr

BRANCH OFFICES & WAREHOUSES



ALGERIA

Eurl Aksa Générateurs Algérie
Zone Industrielle Oued Smar Lot
N° 55 Harrach / Alger / Algerie
T : + 213 23 92 06 56-57-58
contact@aksa-dz.com



CHINA

Aksa Power Generation Co. Ltd.
No.19 Tongjiang North Road,
New District, Changzhou / China
T: + 86 (0) 519 851 50 205
e-mail: aksa@aksapowergen.com



GHANA

Aksa Power Generation (Gana)
11 Trinity Avenue, East Legon,
Greater Accra, Ghana
T : +233 206 99 88 00
e-mail: info@aksaghana.com



IRAQ

Aksa Power Generation (Iraq)
English Village House
No:353 Arbil / Iraq
T : + 964 (0) 770 761 12 20
e-mail: export@aksa.com.tr



INDONESIA

Aksa Power Generation (Endonezya)
Menara Palma Lantai 3 unit 3-03
Jalan HR Rasuna Said Blok X2 Kav.6
Kelurahan Kuningan Timur
Kecamatan Setiabudi Jakarta Selatan,
Jakarta, Indonesia
T: +21 5795 7590



KAZAKHISTAN

Aksa Kazakhstan
89a Suynbay ave.
Almaty city / KAZAKHSTAN
T: +7 (727) 338 48 47
e-mail: info@aksakz.kz



KENYA

Sunflag Industrial Park No:3 Mombasa Rd.
P.O. Box 196-00519 Nairobi / Kenya
T: +254 792 423 359
e-mail: info@aksakenya.com



NETHERLANDS

Aksa Europe
Merwedestraat 48P 3313CS,
Dordrecht/Netherlands
T: +31 (0)6 4170 1172
e-mail: sales@aksaeurope.com



RUSSIA

Aksa Russia
119530, Moscow Ochakovskoe Highway,
29, BC 'WEST PARK'
T : +7 495 710 88 62
e-mail : info@aksarusssia.ru



SINGAPORE

Aksa Far East(Pte.) Ltd.
94 Tuas Avenue 11
639103 Singapore
T : + 65 6863 2832
e-mail: aksafe@aksafareast.com.sg



SUDAN

Aksa Power Generation (Sudan)
Sudan, Khartoum State, Khartoum, Ryad,
Omak Street block 8, Building Number 4,
East Side / Sudan
e-mail : murat@aksasudan.com



SOUTH AFRICA

Aksa Power Generation [South Africa]
109 Roan Crescent, Corporate Park North,
1685, Midrand, Johannesburg
South Africa
T: +27 60 774 64 88
e-mail : aksa@aksa.com.tr



U.A.E.

Power Generation FZE
Po Box:18167 Jebel Ali Free Zone
Warehouse No.RA08 / LC07 Dubai / UAE
T : + 971 4 880 91 40
e-mail: sales@aksa.ae



UNITED KINGDOM

Aksa International (UK) Ltd
Unit 6, Pine Court Walker Road, Bardon Hill
Coalville Leicestershire, LE67 1SZ U.Kingdom
T : + 44 (0) 1530 837 472
e-mail: sales@aksa-uk.com



U.S.A.

Aksa USA
371 Exchange Street
West Monroe, LA 71292
T: +1 318 855 83 77
e-mail: sales@aksausa.com



UZBEKISTAN

Aksa Uzbekistan
18/1, Oybek Street
Tashkent / Uzbekistan
T: + 998 (78) 150 27 47
e-mail: info@aksa.uz



VIETNAM

Aksa Vietnam
28 Ter B Mac Dinh Chi Street Dako
Ward District 1, HCM City - Vietnam
T : + 84 8 391 47 014
e-mail: vietnam@aksapowergen.com



AKSA JENERATÖR SANAYİİ A.Ş.



DECLARATION OF CONFORMITY AB - UYGUNLUK BEYANI

Üretici / Manufacturer : AKSA Jeneratör San. A.Ş.
Adres / Address : Rüzgarlı Bahçe Mah. Özalp Çıkmazı No:10
Kavacak / Beykoz / İstanbul / Türkiye
Ürün Kodu Product Code(s) :

Ürün Açıklaması : Otomatik Tip Kabinli Jeneratör
Production Description : Automatic Generator with Canopy

Deklerasyon / Declaration

Aksa Jeneratör San. A.Ş. olarak, yukarıda bilgileri verilmiş olan ürünün aşağıdaki Avrupa Birliği direktiflerine, standartlara ve bunların gerektirdiği şartlara uygun olduğunu beyan ederiz.

On behalf of AKSA Jeneratör San. A.Ş. , We declare that above information in relation on the supply/manufacture of this in product is in conformity with the below stated standarts, EC directives and provisions of them.

Avrupa Birliği Direktifleri / EC Directives

2006/42/AT : Makine Emniyeti Yönetmeliği
2006/42/EC : Machinery Safety Directive

2014/30/AB : Elektromanyetik Uyumluluk Yönetmeliği
2014/30/EU : Electromagnetic Compatibility Directive

2014/35/AB : Alçak Gerilim Yönetmeliği
2014/35/EU : Low Voltage Directive

Standartlar / Standarts

- TS EN ISO 12100:2010 : Makinelerde Güvenlik - Tasarım İçin Genel Prensipler –Risk Değerlendirilmesi ve risk azaltılması
EN ISO 12100:2010 : Safety of machinery — General principles for design-Risk assessment and risk reduction
- TS EN ISO 3744:2010 : Akustik - Gürültü Kaynaklarının Ses Gücü Seviyelerinin Ses Basıncı Kullanılarak Tayini - Bir Yansıtma Düzlemi Boyunca, Esas Olarak Serbest Bir Alan İçinde Uygulanan Mühendislik Metodu
EN ISO 3744:2010 : Acoustics. Determination of sound power levels of noise sources using sound pressure. Engineering method in an essentially free field over a reflecting plane
- TS EN 60204-1 : Makinelerde güvenlik - Makinelerin elektrik donanımı - Bölüm 1: Genel kurallar
EN 60204-1:2018 : Safety of machinery - Electrical equipment of machines Part 1: General requirements
- TS EN ISO 8528-13:2016 : Gidip gelme hareketli içten yanmalı motor tahrikli alternatif akım jeneratör grupları - Bölüm 13: Emniyet
EN ISO 8528-13:2016 : Reciprocating internal combustion engine driven alternating current generating sets - Part 13: Safety
- TS EN 61000-4-2:2009 : Elektromanyetik Uyumluluk (EMU)-Bölüm 4-2: Deney Ölçme Teknikleri-Elektrostatik Boşalma Bağışıklık Deneyi
BS EN 61000-4-2:2009 : Electromagnetic compatibility (EMC). Testing and Measurement Techniques. Electrostatic Discharge Immunity Test
- TS EN 61000-4-6: : Elektromanyetik Uyumluluk (EMU)-Bölüm 4-6: Deney Ölçme Teknikleri-Radyo Frekans Alanlarının Neden Olduğu Temaslı Rahatsızlıklara Karşı Bağışıklık
BS EN 61000-4-6: 2014 : Electromagnetic compatibility (EMC). Testing and Measurement Techniques. Immunity to Conducted Disturbance Induced By Radio –Frequency Fields
- TS EN 614-1+A1 : Makinelerde güvenlik – Ergonomik tasarım prensipleri-Bölüm 1:Terminoloji ve genel prensipler
EN 614-1:2006+A1(2009): Safety of machinery – Ergonomic design principles – Part 1 : Terminology and general principles

Yayın / Issued by : AKSA Jeneratör San. A.Ş.

Yer - Tarih / Place - Date : İstanbul -

Firma Adına Yetkili : İbrahim YILDIRIM

Name of Authorized Representative

Unvan / Title : Global Üretim Direktörü / Global Production Director

İmza / Signature

AKSA JENERATÖR SANAYİİ A.Ş.



**DECLARATION OF CONFORMITY
AB - UYGUNLUK BEYANI**

Üretici / Manufacturer : **AKSA Jeneratör San. A.Ş.**

Adres / Address : **Rüzgarlı Bahçe Mah. Özalp Çıkmazı No:10
Kavacık / Beykoz / İstanbul / Türkiye**

Ürün Kodu Product Code(s) :

Ürün Açıklaması : **Otomatik Tip Açık Jeneratör**

Production Description : **Automatic Generator with Out Canopy**

Deklerasyon / Declaration

Aksa Jeneratör San. A.Ş. olarak, yukarıda bilgileri verilmiş olan ürünün aşağıdaki Avrupa Birliği direktiflerine, standartlara ve bunların gerektirdiği şartlara uygun olduğunu beyan ederiz.

On behalf of AKSA Jeneratör San. A.Ş. ,We declare that above information in relation on the supply/manufacture of this in product is in conformity with the below stated standards, EC directives and provisions of them.

Avrupa Birliği Direktifleri / EC Directives

2006/42/AT : Makine Emniyeti Yönetmeliği

2006/42/EC : Machinery Safety Directive

2014/30/AB : Elektromanyetik Uyumluluk Yönetmeliği

2014/30/EU : Electromagnetic Compatibility Directive

2014/35/AB : Alçak Gerilim Yönetmeliği

2014/35/EU : Low Voltage Directive

Standartlar / Standards

- TS EN ISO 12100:2010** : Makinelerde Güvenlik - Tasarım İçin Genel Prensipler –Risk Değerlendirilmesi ve risk azaltılması
EN ISO 12100:2010 : Safety of machinery — General principles for design-Risk assessment and risk reduction
- TS EN ISO 3744:2010** : Akustik - Gürültü Kaynaklarının Ses Gücü Seviyelerinin Ses Basıncı Kullanarak Tayini - Bir Yansıtma Düzlemi Boyunca, Esas Olarak Serbest Bir Alan İçinde Uygulanan Mühendislik Metodu
EN ISO 3744:2010 : Acoustics. Determination of sound power levels of noise sources using sound pressure. Engineering method in an essentially free field over a reflecting plane
- TS EN 60204-1** : Makinelerde güvenlik - Makinelerin elektrik donanımı - Bölüm 1: Genel kurallar
EN 60204-1:2018 : Safety of machinery - Electrical equipment of machines Part 1: General requirements
- TS EN ISO 8528-13:2016** : Gidip gelme hareketli içten yanmalı motor tahrikli alternatif akım jeneratör grupları - Bölüm 13: Emniyet
EN ISO 8528-13:2016 : Reciprocating internal combustion engine driven alternating current generating sets - Part 13: Safety
- TS EN 61000-4-2:2009** : Elektromanyetik Uyumluluk (EMU)-Bölüm 4-2: Deney Ölçme Teknikleri-Elektrostatik Boşalma Bağışıklık Deneyi
BS EN 61000-4-2:2009 : Electromagnetic compatibility (EMC). Testing and Measurement Techniques. Electrostatic Discharge Immunity Test
- TS EN 61000-4-6:** : Elektromanyetik Uyumluluk (EMU)-Bölüm 4-6: Deney Ölçme Teknikleri-Radyo Frekans Alanlarının Neden Olduğu Temaslı Rahatsızlıklara Karşı Bağışıklık
BS EN 61000-4-6:2014 : Electromagnetic compatibility (EMC). Testing and Measurement Techniques. Immunity to Conducted Disturbance Induced by Radio-Frequency Fields
- TS EN 614-1+A1** : Makinelerde güvenlik – Ergonomik tasarım prensipleri-Bölüm 1: Terminoloji ve genel prensipler
EN 614-1:2006+A1(2009) : Safety of machinery – Ergonomic design principles – Part 1 : Terminology and general principles

Yayım / Issued by : **AKSA Jeneratör San. A.Ş.**

Yer - Tarih / Place - Date : **İstanbul -**

Firma Adına Yetkili : **İbrahim YILDIRIM**

Name of Authorized Representative

Unvan / Title : **Global Üretim Direktörü / Global Production Director**

İmza / Signature

aksa
JENERATÖR

MALIN;	
CİNSİ	JENERATÖR
MARKASI	AKSA
MODELİ / SERİ NUMARASI	
MALIN TÜKETİCİYE TESLİM TARİHİ	
MALIN TÜKETİCİYE TESLİM YERİ	
GARANTİ / AZAMI TAMİR SÜRESİ	2 YIL / 20 İŞGÜNÜ

İMALATÇI VEYA İTHALATÇI FİRMANIN

ÜNVANI	AKSA JENERATÖR SANAYİ ANONİM ŞİRKETİ
MERKEZ ADRESİ	RÜZGARLI BAĞÇE MAH. ÖZALP ÇIKMAZI NO:10 KAVACIK - BEYOZ - İSTANBUL / TÜRKİYE
TEL / FAX / E-MAIL	0.216 681 00 00 / 0.216 681 57 91
YETKİLİ KİŞİ / ÜNVANI	GENEL MÜDÜR
YETKİLİ KİŞİ İMZA / KAŞE	

SATICI FİRMANIN;

ÜNVANI	
ADRESİ	
TEL/FAX/ E-MAIL	
FATURA TARİHİ / NO	
YETKİLİ KİŞİ / ÜNVANI YETKİLİ KİŞİ İMZA / KAŞE	

GARANTİ ŞARTLARI

1. Garanti süresi, malın teslim tarihinden itibaren başlar ve tüketiciler için 2 yıldır. Malı mesleki ve ticari amaçlı olarak kullanan Tacierler(müşteri) için ise garanti süresi, firmalar arası yapılan sözleşme ile belirlenir.
2. Malın bütün parçaları dahil olmak üzere tamamı garanti kapsamıdadır.
3. Malın aygılı olduğunu anlaşılması durumunda tüketici, 6502 sayılı Tüketicinin Korunması Hakkında Kanununun 11 inci maddesinde yer alan:
 - a- Sözleşmeden dönme,
 - i- Satış bedelinden indirimi isteme,
 - ii- Satış bedelinden indirimi isteme,
 - iii- Ücretsiz onarımını isteme,
 - iv- Satılan aygıptı bir misli ile değiştirilmesini isteme,
 - b- Satılan aygıptı bir misli ile değiştirilmesini isteme, haklarından birini kullanabilir.
4. Tüketicinin bu haklardan ücretsiz onarım hakkını seçmesi durumunda satıcı, işçilik masraflı, değiştirilen parça bedelî ya da başka herhangi bir ad altında hiçbir ücret talep etmeksizin malın onarımını yapmak veya yaptırmakta yükümlüdür. Tüketici, ücretsiz onarım hakkını üretici veya ithalataçya karşı da kullanabilir. Satıcı, üretici ve ithalataç tüketicinin bu hakkını kullanmasından müstesna olarak sorumludur.
5. Tüketicinin, ücretsiz onarım hakkını kullanması halinde malın:
 - Garanti süresi içinde tekrar arızalanması,
 - Tamiri için gereken zaman süresinin aşılması,
 - Tamirini mümkün olmadığında, yetkili servis istasyonuna, yetkili servis istasyonuna veya malın yatacağı taraftan bir raporda belirlenmesi durumunda talep edebilir. Satıcı, tüketicinin talebini reddedemez. Bu talebin yerine getirilmesini durumunda satıcı, üretici ve ithalataç müteselsilen sorumludur.
6. Malın tamiri süresi 20 iş günü geçemez. Bu süre, garanti süresi içerisinde mala ilişkin arızanın yetkili servis istasyonuna veya satıcıya bildirim tarihinde, garanti süresi dışında ise malın yetkili servis istasyonuna teslim tarihinden itibaren başlar. Malın arızasının 10 iş günü içerisinde giderilmesini halinde, üretici veya ithalataç malın tamiri tamamlandıncaya kadar, benzer özelliklere sahip başka bir malı tüketicinin kullanımına tabii kullanıma klavuzunda yer alan hususlara aykırı kullanımasından kaynaklanan arızalar garanti kapsamı dışındadır.
7. Malın kullanıma klavuzunda yer alan hususlara aykırı kullanımasından kaynaklanan arızalar garanti kapsamı dışındadır.
8. Tüketici, garantiden doğan haklarının kullanılmasını ile ilgili olarak çıkabilecek uyuşmazlıklarda yerleşim yerinin bulunduğu veya tüketici işleminin yapıldığı yerdeki Tüketici Hakem Heyetince veya Tüketici Halkemnesine başvurabilir.
9. Satıcı tarafından bu Garanti Belgesinin verilmesi durumunda, tüketici Gümrük ve Ticaret Bakanlığı Tüketicinin Korunması ve Piyasa Gözetimi Genel Müdürlüğüne başvurabilir.

Not: Servisin Müddetle ilgili sorularında müşteri tarafından bu belge veya fotoğrafların ibraz edilmesi zorundadır.

GARANTİ DIŞI DURUMLAR

1. Satın alınan jeneratörlerin devreye alma işlemleri AKSA Jeneratör yetkili servislerince yapılmalı, müşterinin kendisi veya başka bir servise yaptırılmamalıdır. Aksi durumda Jeneratör garantisi kapsamı dışına çıkar. Yapılan devreye alma işlemi, sadece işlemin yapıldığı mekân için geçerli olup, yani bir yerde kullanımı için tekrar AKSA Jeneratör yetkili servislerince devreye alınmalıdır. İkinci defa yapılacak devreye alma işleminin ücretini müşteri karşılayacaktır.
2. Garanti süresi içerisindeki bütün jeneratörlerimizin, periyodik bakım çizelgesinde belirtilen tüm bakımları, Akşa Jeneratörün yetkili servislerine ücretli kararlaştırılmıştır. Bu bakımlardan herhangi birisinin yapılması durumunda jeneratör garantisi kapsamı dışına çıkar.
3. AKSA Jeneratör tarafından onaylanmayan malzeme kullanımı sonucu gerçekleşen arızalar, ihmal sonucu oluşan arızalar, yanlış kullanıma, uygun olmayan güçte kullanıma, yanlış yerleşim, uygun olmayan şartlardaki depolama durumlarından kaynaklanacak arızalarda ve yetkili olmayan servisler ve şahıslar tarafından tamiri, bakım veya müdahalelerde jeneratör garantisi kapsamı dışına çıkar.
4. Satın alınan jeneratör 6 ay içerisinde devreye alınmayacaksa, jeneratöre ait depolama koşulları sağlanarak koyuldu ile bekletilmelidir. Garanti süresi içerisindeki bir makinenin depolama (konservasyonu) işlemini yaptırılması durumunda jeneratör garantisi kapsamı dışına çıkar.
5. Kamyon üsü teslimlerde, nakliye sorumluluğu, indirme sorumluluğu da dahil olmak üzere kamyon üstünde tesliminden sonra, start işlemine kadar makinenin uygun şartlarda muhafaza edilmesi tamamen müşterinin sorumluluğundadır. Bu esnada oluşacak hasar ve arızalarda jeneratör garantisi kapsamı dışına çıkar.
6. Soğutma sistemine, silindir gömleği veya bloğunda karıncılaşma, erozyon ve tırtıl oluşması için eklenmesi gereken kimyasalların eklenmesi durumunda, oluşan arızalarda jeneratör garantisi kapsamı dışına çıkar.
7. Satın alınan jeneratörlere garanti süresi içerisinde, orijinal ekipmanları ve projeksi harcinde senkron, ilave kontrol ünitesi, pano, transfer pano vb. ilave ekipman veya proje yapılamaz. Akşa Jeneratörün onayı olmadan yapılmış jeneratör garantisi kapsamı dışına çıkar.
8. Deprem, sel, su baskını, yıldırım düşmesi ve benzeri doğal afetler gibi çevresel etkilere ve sebebeden kaynaklanan arızalarda jeneratör garantisi kapsamı dışına çıkar.
9. Jeneratör gücüne uygun seçilen sebekte kontaklıdır. Üzerinden, jeneratör nominal akımından fazla akım çekilmesinden kaynaklanacak sebekte kontaklıdır, sarf redresörü ve ısıtıcı gibi ünitelerde oluşacak arızalarda Akşa Jeneratör sorumlu değildir.
10. Kullanılan yakıt, yağ ve soğutma suyu kullanıma kitapçıklarında verilen özelliklere sahip olmalıdır. Aksi halde oluşacak arıza ve hasarlarda jeneratör garantisi kapsamı dışına çıkar.
11. Jeneratör uzun süre çalışmazsa aküsü boşalabilir. Motorun yağlanması, uzun ömürlü olması ve akünün sarılı için jeneratörün haftada 1 gün çalıştırılması gerekmektedir. Aksi halde oluşacak arızalarda jeneratör garantisi kapsamı dışına çıkar.

Genel Müdürlük / Head Office

TÜRKİYE / TURKEY
Rüzgarlı Bahçe Mah.
Selvi Çıkmazı No:10, 34805
Kavacık, Beykoz - İstanbul
T : +90 216 681 00 00
E : aksa@aksa.com.tr

Aksa Servis / Aksa Service

TÜRKİYE / TURKEY
Murat Bey Beldesi,
Güney girişi Cad. No:8
34540 Catalca / İSTANBUL
T : +90 212 887 11 11
E : info@aksaservis.com.tr

Aksa Kiralama / Aksa Rental

TÜRKİYE / TURKEY
Murat Bey Beldesi,
Güney girişi Cad. No:8
34540 Catalca / İSTANBUL
T : +90 212 887 12 12
E : aksakiralama@aksakiralama.com.tr

B.A.E. / U.A.E.
Aksa Middle East
Post Box. No:18167 Jebel ali Free Zone
Dubai - United Arab Emirates
T : +971 4 880 91 40
E : sales@aksa.ae

Fabrikalar / Factories

TÜRKİYE / TURKEY
Yıldırım Beyazıt Osb Mh.
8. Cd. No:1/2/A - 1/3A, 59850 Tekirdağ
T : +90 282 737 96 00
E : aksa@aksa.com.tr

ÇİN / CHINA
No.19 Tongjiang North Road,
New District, Changzhou / China
T : +86 (0) 519 856 01 250
E : aksa@aksapowergen.com

ABD / USA
371 Exchange Street
West Monroe, LA 71292
T : +1 318 855 83 77
E : sales@aksausa.com

HOLLANDA / NETHERLANDS
Merwedestraat 48P 3313CS,
Dordrecht/Netherlands
T : +31 (0) 78-204 9129
E : sales@aksaeurope.com